



RoadMax

9100 SERIES

TRAFFIC DRUM

Our durable orange barrels are designed to withstand the rigors of daily use and provide clear, visible guidance to drivers. Easy to set up and move, traffic drums are a safe and reliable solution for any construction or road maintenance project. Protect your workers and improve traffic flow with traffic drums today.



ROADMAX 9100

DRUM-4-4EG-MAX	ROADMAX Drum with (2) 4" Orange 3M Engineering Grade Bands (2) 4" white 3M Engineering Grade Bands
DRUM-4-4HI-MAX	ROADMAX Drum with (2) 4" Orange 3M High Intensity Grade Bands (2) 4" white 3M High Intensity Grade Bands
DRUM-4-6DGR-MAX	ROADMAX Drum with (2) 6" Orange 3M Diamond Grade Bands (2) 6" white 3M Diamond Grade Bands
DRUM-4-6HI-MAX	ROADMAX Drum with (2) 6" Orange 3M High Intensity Grade Bands (2) 6" white 3M High Intensity Grade Bands
DRUM-NS-MAX	ROADMAX Drum with no sheeting

SPECIFICATIONS

Material: Impact-Resistant Polyethylene
 Color: UV-Stabilized Highway Orange
 Body Height: 36" (0.92 m)
 Overall Height: 41.38" (1.05 m)
 Weight: 8.0 LB (3.5 kg)
 Minimum Diameter: 18" (46 cm)
 Base Option: 22LB Tire Ring



**TIRE WALL AVAILABLE
AND SOLD SEPARATE.**

FEATURES

- Rounded ergonomic handle for easy access with a comfortable grip
- Recessed reflective band tiers for long-lasting protection of sheeting
- Four anti-rotation claws will keep drums facing traffic
- Built-in sheeting edge protector guards against wear during stacking
- Five-tier design for better visibility in heavy traffic
- Double light mounts on handle for added convenience
- Domed top sheds debris and water
- Ribbed bottom lip for easy base attachment
- Two-piece top & base design allows dragging without separation
- Two-piece breakaway feature allows controlled separation on impact
- UV-stabilized bright orange polyethylene protects from sun damage



Base NOT included; order separately



RoadMax 9100 SERIES TRAFFIC DRUM

Our durable orange barrels are designed to withstand the rigors of daily use and provide clear, visible guidance to drivers. Easy to set up and move, traffic drums are a safe and reliable solution for any construction or road maintenance project. Protect your workers and improve traffic flow with traffic drums today.



ROADMAX 9100 **DRUM-4-4EG-MAX**

ROADMAX Drum with
(2) 4" Orange 3M Engineering Grade Bands
(2) 4" White 3M Engineering Grade Bands

SPECIFICATIONS

Material: Impact-Resistant Polyethylene
Color: UV-Stabilized Highway Orange
Body Height: 36" (0.92 m)
Overall Height: 41.38" (1.05 m)
Weight: 8.0 LB (3.5 kg)
Minimum Diameter: 18" (46 cm)
Base Option: 22LB Tire Ring

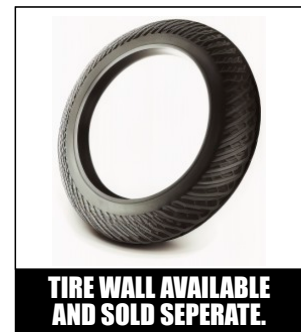

FEATURES

- Rounded ergonomic handle for easy access with a comfortable grip
- Recessed reflective band tiers for long-lasting protection of sheeting
- Four anti-rotation claws will keep drums facing traffic
- Built-in sheeting edge protector guards against wear during stacking
- Five-tier design for better visibility in heavy traffic
- Double light mounts on handle for added convenience
- Domed top sheds debris and water
- Ribbed bottom lip for easy base attachment
- Two-piece top & base design allows dragging without separation
- Two-piece breakaway feature allows controlled separation on impact
- UV-stabilized bright orange polyethylene protects from sun damage



Base NOT included; order separately

DRUM-4-4EG-MAX

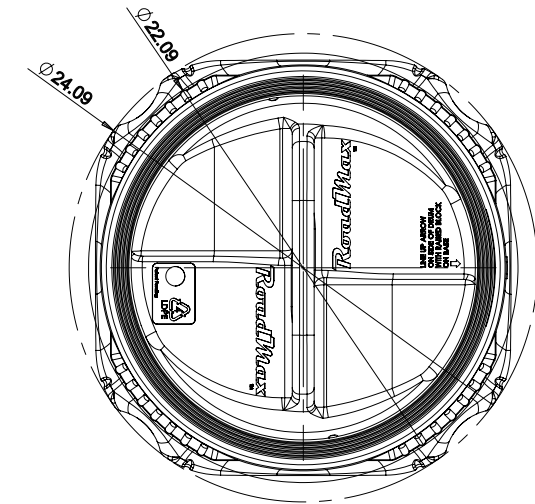

DETAIL

SCALE 2 : 1

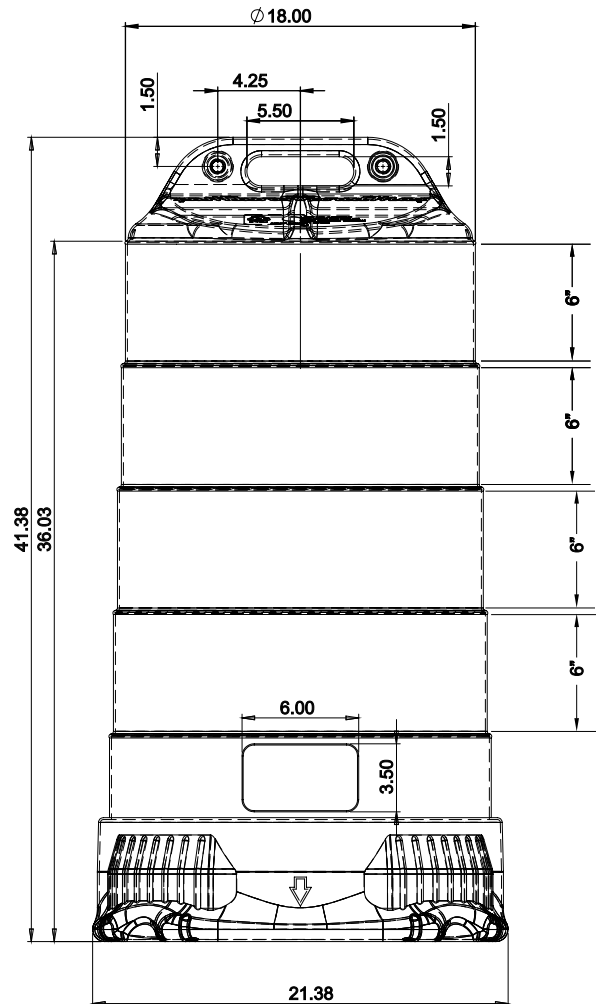
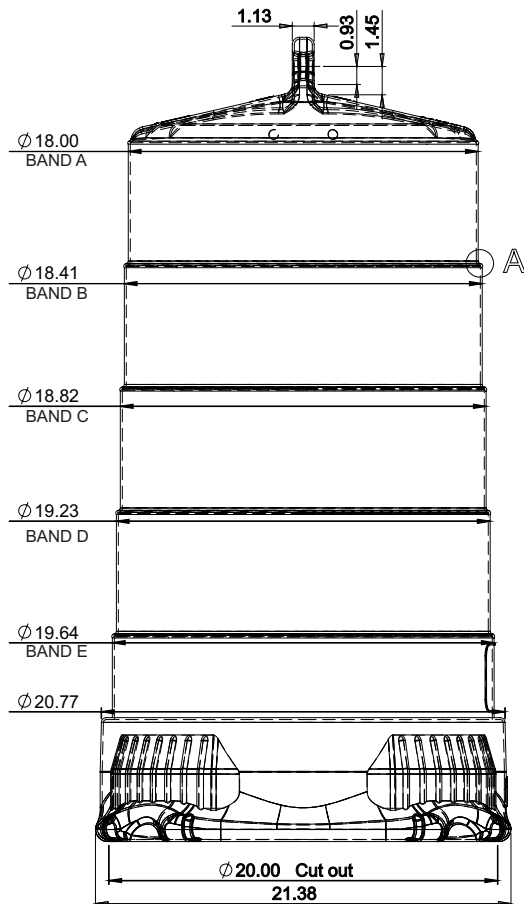
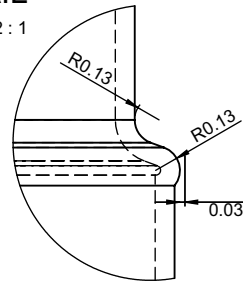

MATERIAL: IMPACT-RESISTANT POLYETHYLENE
COLOR: UV-STABILIZED HIGHWAY ORANGE
BODY HEIGHT: 36" (0.92 M)
OVERALL HEIGHT: 41.38" (1.05 M)
WEIGHT: 8.0 LB (3.5 KG)
MINIMUM DIAMETER: 18" (46 CM)
BASE OPTION: 22LB TIRE RING

BAND	CIRCUMFERENCE	SQ. FT
A	56.57"	1.77 FT
B	57.83"	1.84 FT
C	59.12"	1.84 FT 2
D	60.41"	2.02 FT
E	61.70"	22.34 FT

ROADMAX 9100 DRUM-4-4EG-MAX

ROADMAX Drum with
 (2) 4" Orange 3M Engineering Grade Bands
 (2) 4" White 3M Engineering Grade Bands



Eastern Metal
SIGNS & SAFETY

607-734-2295
 CUSTOMERSERVICE@USA-SIGN.COM



RoadMax

9100 SERIES

TRAFFIC DRUM

Our durable orange barrels are designed to withstand the rigors of daily use and provide clear, visible guidance to drivers. Easy to set up and move, traffic drums are a safe and reliable solution for any construction or road maintenance project. Protect your workers and improve traffic flow with traffic drums today.



ROADMAX 9100

DRUM-4-4HI-MAX

ROADMAX Drum with

- (2) 4" Orange 3M High Intensity Grade Bands
- (2) 4" white 3M High Intensity Grade Bands

SPECIFICATIONS

Material: Impact-Resistant Polyethylene
Color: UV-Stabilized Highway Orange
Body Height: 36" (0.92 m)
Overall Height: 41.38" (1.05 m)
Weight: 8.0 LB (3.5 kg)
Minimum Diameter: 18" (46 cm)
Base Option: 22LB Tire Ring



FEATURES

- Rounded ergonomic handle for easy access with a comfortable grip
- Recessed reflective band tiers for long-lasting protection of sheeting
- Four anti-rotation claws will keep drums facing traffic
- Built-in sheeting edge protector guards against wear during stacking
- Five-tier design for better visibility in heavy traffic
- Double light mounts on handle for added convenience
- Domed top sheds debris and water
- Ribbed bottom lip for easy base attachment
- Two-piece top & base design allows dragging without separation
- Two-piece breakaway feature allows controlled separation on impact
- UV-stabilized bright orange polyethylene protects from sun damage



Base NOT included; order separately

DRUM-4-4HI-MAX

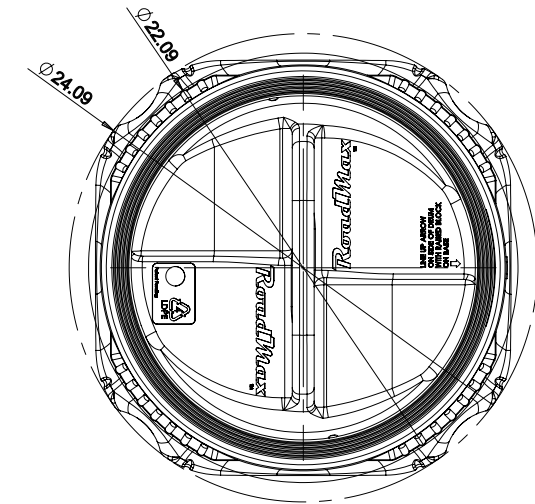

DETAIL

SCALE 2 : 1

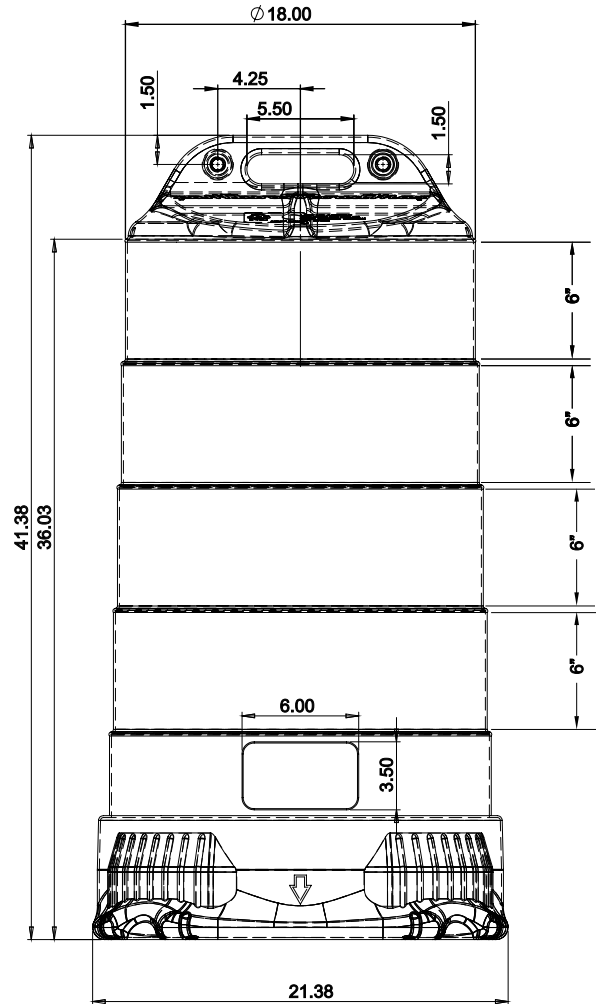
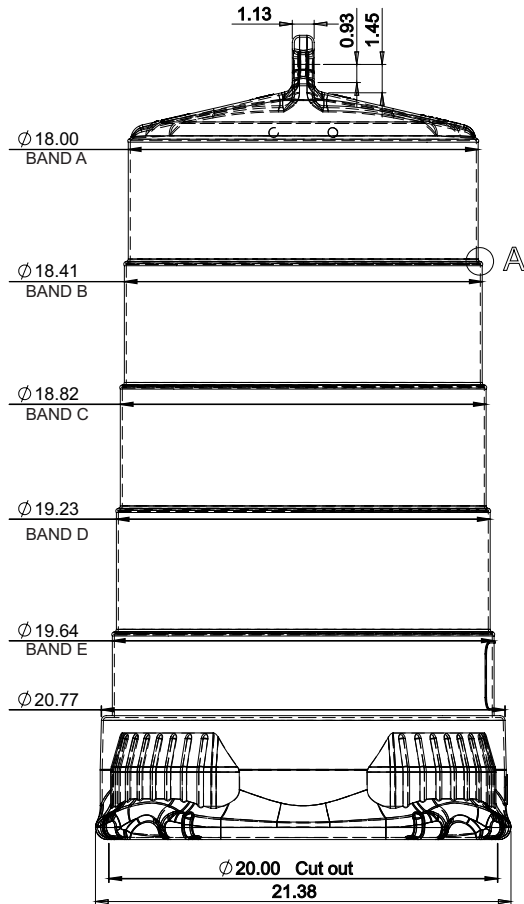
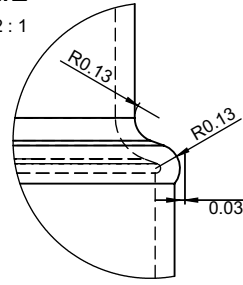

MATERIAL: IMPACT-RESISTANT POLYETHYLENE
COLOR: UV-STABILIZED HIGHWAY ORANGE
BODY HEIGHT: 36" (0.92 M)
OVERALL HEIGHT: 41.38" (1.05 M)
WEIGHT: 8.0 LB (3.5 KG)
MINIMUM DIAMETER: 18" (46 CM)
BASE OPTION: 22LB TIRE RING

ROADMAX 9100 DRUM-4-4HI-MAX

ROADMAX Drum with
 (2) 4" Orange 3M High intensity Grade Bands
 (2) 4" white 3M High Intensity Grade Bands

BAND	CIRCUMFERENCE	SQ. FT
A	56.57"	1.77 FT
B	57.83"	1.84 FT
C	59.12"	1.84 FT 2
D	60.41"	2.02 FT
E	61.70"	22.34 FT



Eastern Metal
 SIGNS & SAFETY

607-734-2295
 CUSTOMERSERVICE@USA-SIGN.COM



RoadMax

9100 SERIES

TRAFFIC DRUM

Our durable orange barrels are designed to withstand the rigors of daily use and provide clear, visible guidance to drivers. Easy to set up and move, traffic drums are a safe and reliable solution for any construction or road maintenance project. Protect your workers and improve traffic flow with traffic drums today.



ROADMAX 9100

DRUM-4-6DGR-MAX

ROADMAX Drum with

- (2) 6" Orange 3M Diamond Grade Bands
- (2) 6" White 3M Diamond Grade Bands

SPECIFICATIONS

Material: Impact-Resistant Polyethylene
Color: UV-Stabilized Highway Orange
Body Height: 36" (0.92 m)
Overall Height: 41.38" (1.05 m)
Weight: 8.0 LB (3.5 kg)
Minimum Diameter: 18" (46 cm)
Base Option: 22LB Tire Ring



FEATURES



- Rounded ergonomic handle for easy access with a comfortable grip
- Recessed reflective band tiers for long-lasting protection of sheeting
- Four anti-rotation claws will keep drums facing traffic
- Built-in sheeting edge protector guards against wear during stacking
- Five-tier design for better visibility in heavy traffic
- Double light mounts on handle for added convenience
- Domed top sheds debris and water
- Ribbed bottom lip for easy base attachment
- Two-piece top & base design allows dragging without separation
- Two-piece breakaway feature allows controlled separation on impact
- UV-stabilized bright orange polyethylene protects from sun damage

Base NOT included; order separately

DRUM-4-GDGR-MAX

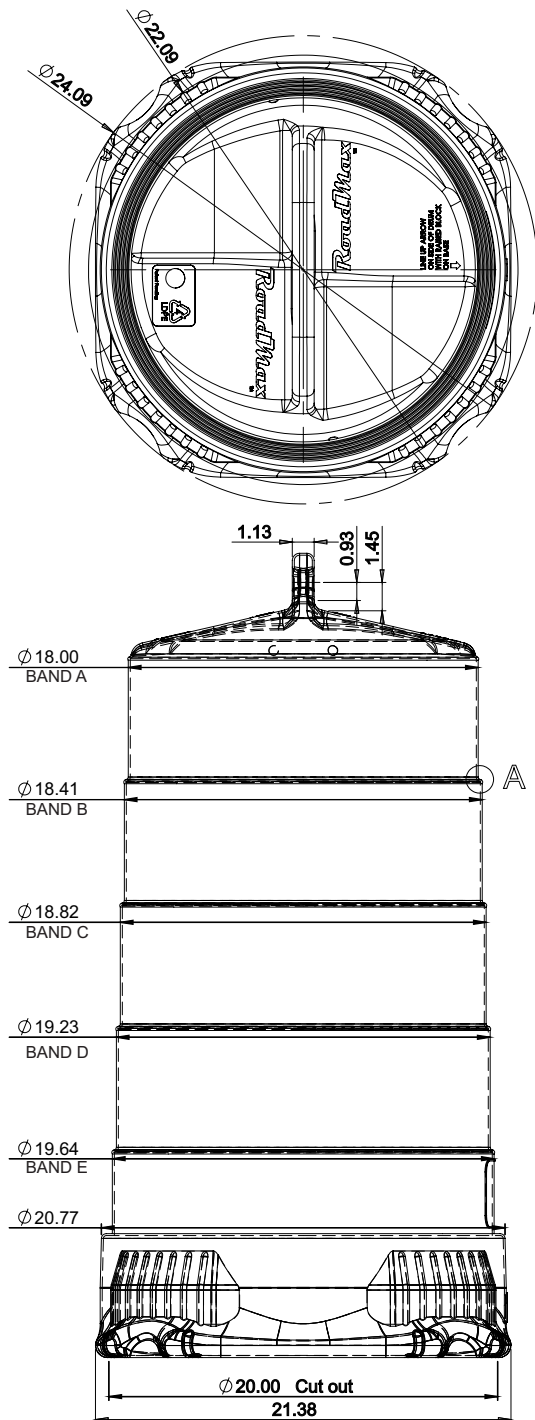

DETAIL

SCALE 2 : 1

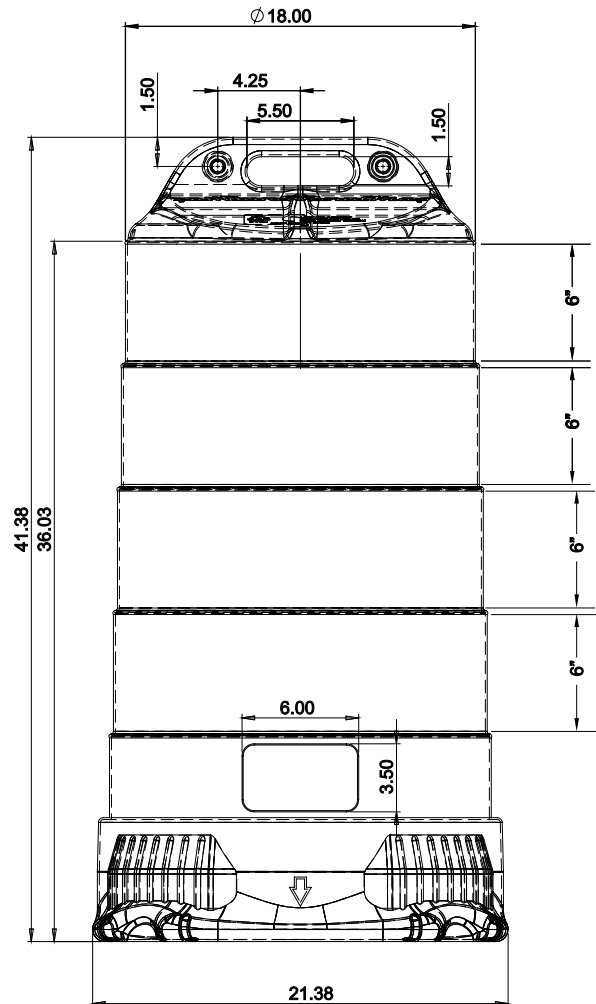
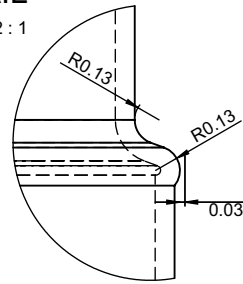

MATERIAL: IMPACT-RESISTANT POLYETHYLENE
COLOR: UV-STABILIZED HIGHWAY ORANGE
BODY HEIGHT: 36" (0.92 M)
OVERALL HEIGHT: 41.38" (1.05 M)
WEIGHT: 8.0 LB (3.5 KG)
MINIMUM DIAMETER: 18" (46 CM)
BASE OPTION: 22LB TIRE RING

BAND	CIRCUMFERENCE	SQ. FT
A	56.57"	1.77 FT
B	57.83"	1.84 FT
C	59.12"	1.84 FT 2
D	60.41"	2.02 FT
E	61.70"	22.34 FT

ROADMAX 9100 DRUM-4-6DGR-MAX

ROADMAX Drum with
 (2) 6" Orange 3M Diamond Grade Bands
 (2) 6" White 3M Diamond Grade Bands



607-734-2295
 CUSTOMERSERVICE@USA-SIGN.COM



RoadMax

9100 SERIES

TRAFFIC DRUM

Our durable orange barrels are designed to withstand the rigors of daily use and provide clear, visible guidance to drivers. Easy to set up and move, traffic drums are a safe and reliable solution for any construction or road maintenance project. Protect your workers and improve traffic flow with traffic drums today.



ROADMAX 9100

DRUM-4-6HI-MAX

ROADMAX Drum with
(2) 6" Orange 3M High Intensity Grade Bands
(2) 6" White 3M High intensity Grade Bands

SPECIFICATIONS

Material: Impact-Resistant Polyethylene
Color: UV-Stabilized Highway Orange
Body Height: 36" (0.92 m)
Overall Height: 41.38" (1.05 m)
Weight: 8.0 LB (3.5 kg)
Minimum Diameter: 18" (46 cm)
Base Option: 22LB Tire Ring



FEATURES

- Rounded ergonomic handle for easy access with a comfortable grip
- Recessed reflective band tiers for long-lasting protection of sheeting
- Four anti-rotation claws will keep drums facing traffic
- Built-in sheeting edge protector guards against wear during stacking
- Five-tier design for better visibility in heavy traffic
- Double light mounts on handle for added convenience
- Domed top sheds debris and water
- Ribbed bottom lip for easy base attachment
- Two-piece top & base design allows dragging without separation
- Two-piece breakaway feature allows controlled separation on impact
- UV-stabilized bright orange polyethylene protects from sun damage



Base NOT included; order separately

DRUM-4-GHI-MAX

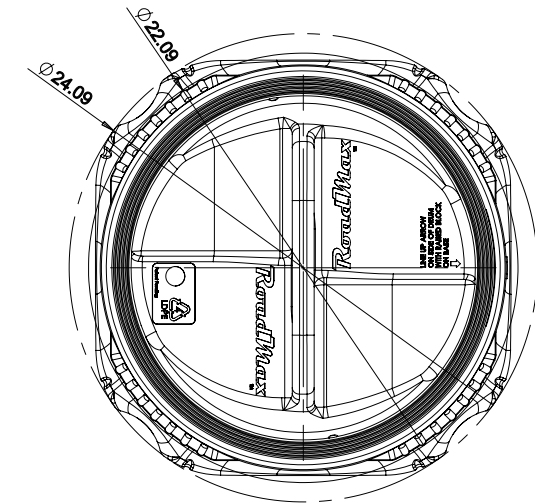

DETAIL

SCALE 2 : 1

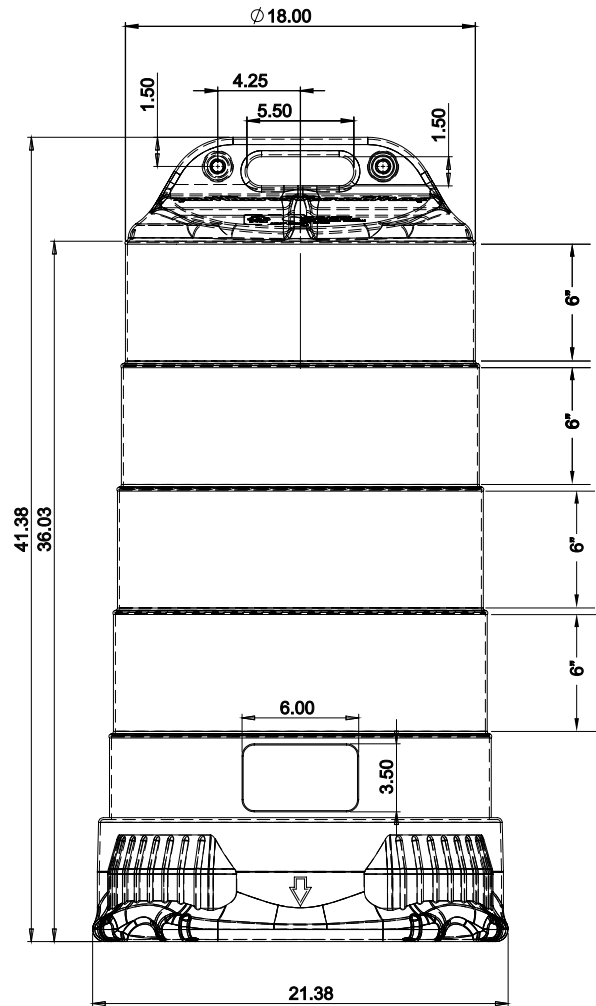
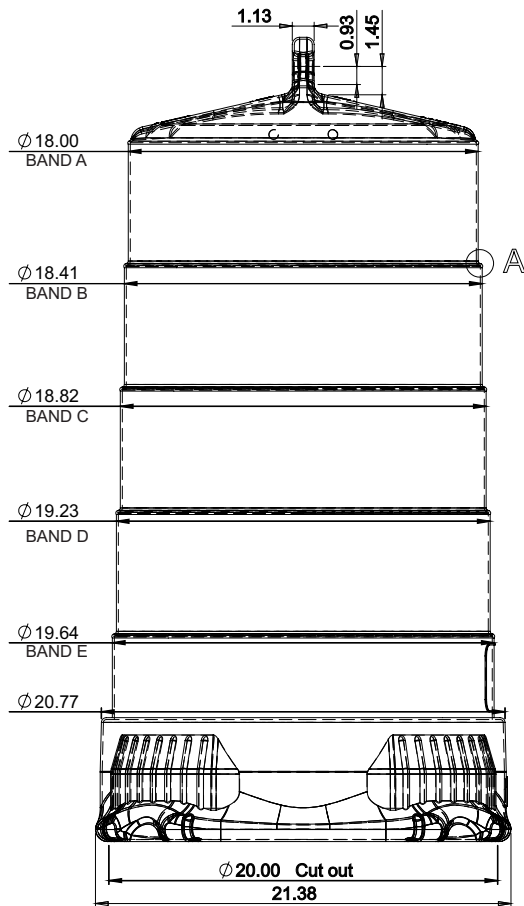
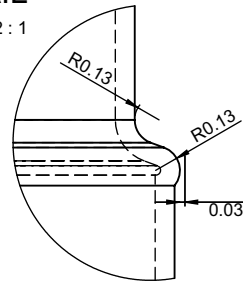

MATERIAL: IMPACT-RESISTANT POLYETHYLENE
COLOR: UV-STABILIZED HIGHWAY ORANGE
BODY HEIGHT: 36" (0.92 M)
OVERALL HEIGHT: 41.38" (1.05 M)
WEIGHT: 8.0 LB (3.5 KG)
MINIMUM DIAMETER: 18" (46 CM)
BASE OPTION: 22LB TIRE RING

BAND	CIRCUMFERENCE	SQ. FT
A	56.57"	1.77 FT
B	57.83"	1.84 FT
C	59.12"	1.84 FT 2
D	60.41"	2.02 FT
E	61.70"	22.34 FT

ROADMAX 9100 DRUM-4-6HI-MAX

ROADMAX Drum with
 (2) 6" Orange 3M High Intensity Grade Bands
 (2) 6" White 3M High Intensity Grade Bands



607-734-2295
 CUSTOMERSERVICE@USA-SIGN.COM



RoadMax

9100 SERIES

TRAFFIC DRUM

Our durable orange barrels are designed to withstand the rigors of daily use and provide clear, visible guidance to drivers. Easy to set up and move, traffic drums are a safe and reliable solution for any construction or road maintenance project. Protect your workers and improve traffic flow with traffic drums today.



ROADMAX 9100

DRUM-NS-MAX

ROADMAX Drum with No Sheeting.

SPECIFICATIONS

Material: Impact-Resistant Polyethylene
Color: UV-Stabilized Highway Orange
Body Height: 36" (0.92 m)
Overall Height: 41.38" (1.05 m)
Weight: 8.0 LB (3.5 kg)
Minimum Diameter: 18" (46 cm)
Base Option: 22LB Tire Ring



**TIRE WALL AVAILABLE
AND SOLD SEPERATE.**

FEATURES

- Rounded ergonomic handle for easy access with a comfortable grip
- Recessed reflective band tiers for long-lasting protection of sheeting
- Four anti-rotation claws will keep drums facing traffic
- Built-in sheeting edge protector guards against wear during stacking
- Five-tier design for better visibility in heavy traffic
- Double light mounts on handle for added convenience
- Domed top sheds debris and water
- Ribbed bottom lip for easy base attachment
- Two-piece top & base design allows dragging without separation
- Two-piece breakaway feature allows controlled separation on impact
- UV-stabilized bright orange polyethylene protects from sun damage



Base NOT included; order separately

DRUM-4-GHI-MAX

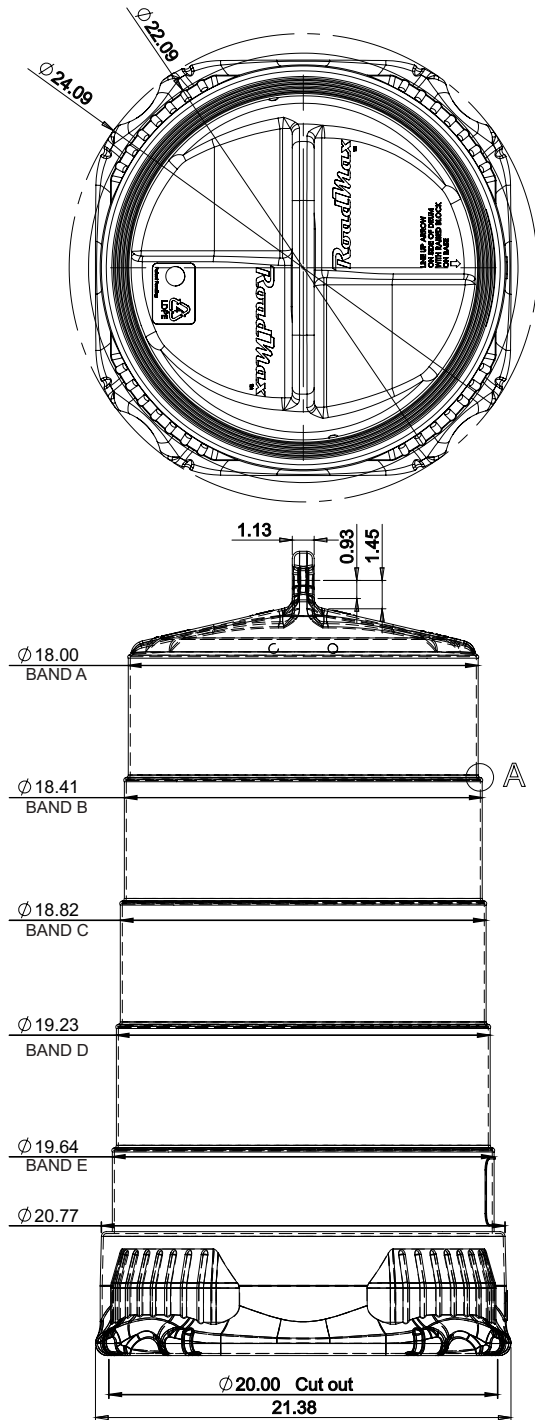

DETAIL

SCALE 2 : 1

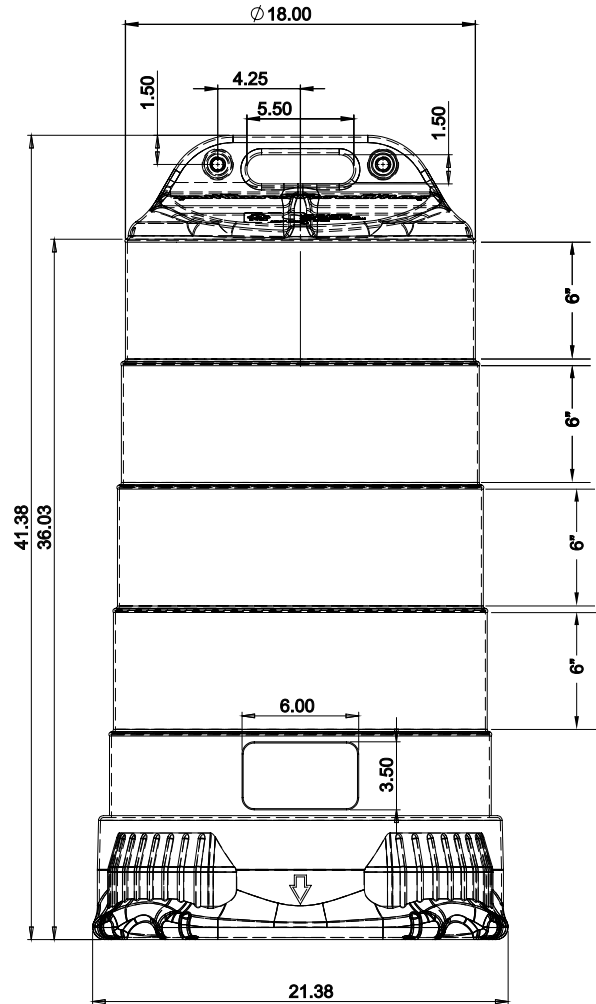
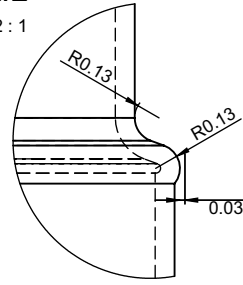

MATERIAL: IMPACT-RESISTANT POLYETHYLENE
COLOR: UV-STABILIZED HIGHWAY ORANGE
BODY HEIGHT: 36" (0.92 M)
OVERALL HEIGHT: 41.38" (1.05 M)
WEIGHT: 8.0 LB (3.5 KG)
MINIMUM DIAMETER: 18" (46 CM)
BASE OPTION: 22LB TIRE RING

BAND	CIRCUMFERENCE	SQ. FT
A	56.57"	1.77 FT
B	57.83"	1.84 FT
C	59.12"	1.84 FT 2
D	60.41"	2.02 FT
E	61.70"	22.34 FT

ROADMAX 9100 DRUM-NS-MAX

ROADMAX Drum with No Sheeting.



Eastern Metal
SIGNS & SAFETY

607-734-2295
CUSTOMERSERVICE@USA-SIGN.COM